



3/4 & 1Ton

1 1/2 Ton

3 Ton

6 Ton

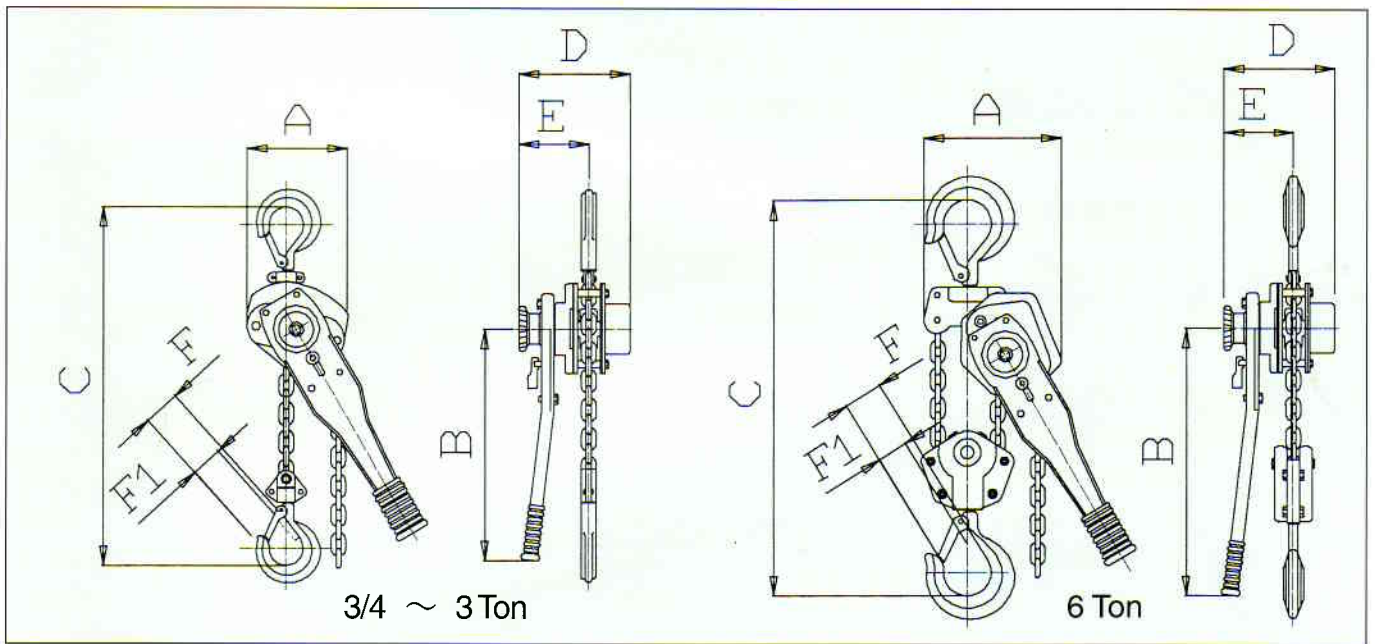

3/4 ~ 3Ton

6 Ton

**■ DIMENSIONS IN mm (inch) :**

CAP.	3/4 Ton	1 Ton	1 1/2 Ton	3 Ton	6 Ton
A	128 ( 5.04 )	128 ( 5.04 )	154 ( 6.06 )	182 ( 7.17 )	242 ( 9.53 )
B	240 ( 9.45 )	240 ( 9.45 )	360 ( 14.17 )	360 ( 14.17 )	360 ( 14.17 )
C	275 ( 10.8 )	295 ( 11.61 )	320 ( 12.60 )	400 ( 15.75 )	570 ( 22.44 )
D	158 ( 6.22 )	158 ( 6.22 )	172 ( 6.77 )	195 ( 7.68 )	195 ( 7.68 )
E	99 ( 3.90 )	99 ( 3.90 )	104 ( 4.09 )	108 ( 4.25 )	108 ( 4.25 )
F	30 ( 1.18 )	34 ( 1.34 )	38 ( 1.50 )	43 ( 1.69 )	57 ( 2.24 )
F1	26 ( 1.02 )	30 ( 1.18 )	34 ( 1.34 )	38 ( 1.50 )	52 ( 2.05 )

- NOTES :**
- ◆ The above table contains our hoist with the standard lift. Extra long lift will be available on specific orders.
  - ◆ To reach the latest engineering standards, our products are subject to any modifications without prior notification.