



TABLE OF CONTENTS

SAFETY INSTRUCTIONS	1
DEFINITIONS	1
SPECIFICATIONS	2
INSTALLATION INSTRUCTIONS	2
OPERATING INSTRUCTIONS	3
Positioning the Strut Assembly	3
Disassembly	6
Reassembly	7
MAINTENANCE	7
REPAIR PARTS	8
WARRANTY	10

SAFETY INSTRUCTIONS

- NEVER allow unauthorized personnel to operate this product.
- NEVER use this product for anything other than its intended use.
- THOROUGHLY train new employees in the proper use and care of this product.
- PROHIBIT unauthorized personnel from being in shop area while this product is in use.

DEFINITIONS

- **CAUTION:** Indicates a potentially hazardous situation, which if not avoided, may result in damage to property or minor personal injury.
- **HAZARD:** A source of potential injury to a person.
- **MAINTENANCE:** Those actions that preserve the correct and proper conditions under which the machine shall be used. This may include adjustment, replacement of wear items, lubrication and cleaning, but not modifications or repair of damage.
- **MAY:** This word is understood to be permissive.
- **MUST:** This word is understood to be mandatory.
- **OPERATION:** The correct and proper use of the machine as described in this manual.
- **SAFETY ALERT SYMBOL:** A symbol that indicates a potential personal safety hazard. It is composed of an equilateral triangle surrounding an exclamation point.
- **SHALL:** This word is understood to be mandatory.
- **SHOULD:** This word is understood to be advisory.
- **WARNING:** Indicates a potentially hazardous situation, which if not avoided, may result in death or serious personal injury.

CAUTION

- ◆ Before using this product, read and fully understand the operating instructions and all decals on the product. This is necessary to prevent injury to the operator and damage to the product.
- ◆ Do not attempt to use this product for anything other than its intended purpose.
- ◆ Do not use this product if it is visibly worn, distorted or damaged.
- ◆ Always check condition of rubber hook pads on all six hooks before using this tool. Replace if damaged or missing.
- ◆ Always wear appropriate eye protection.
- ◆ Inspect the spring of the strut assembly for any damage or corrosion. Spring breakage during compression could cause

WARNING

- ◆ Failure to properly position the strut assembly in tool could result in serious injury from sudden release of the strut assembly parts.

SPECIFICATIONS

Max. Spring Compression Capacity	3000 lbs (1361 kgs)
Min./Max. Spring Diameters	3.5 / 11.5 in (9 / 29 cm)
Packaged Dimensional data	18.5 x 20 x 43.63 in (47 x 51 x 111 cm)
Shipping Weight	95 lbs (43 kgs)

INSTALLATION INSTRUCTIONS

1. Unpack and remove the unit from the shipping carton.
2. Inspect the unit for any visible damage.
3. Install on a solid vertical wall or post. (Can also be installed on an OPTIONAL benchmount and portable cart)
4. Anchor the unit to the wall or post utilizing the two holes in the back plate. Make sure there is no movement between the back plate and wall or post.

OPERATING INSTRUCTIONS

Step 1. Positioning the Strut Assembly

- A) Adjust lower right hook to a position just below the lower center hook. Adjust lower left hook to a position just above the lower center hook.

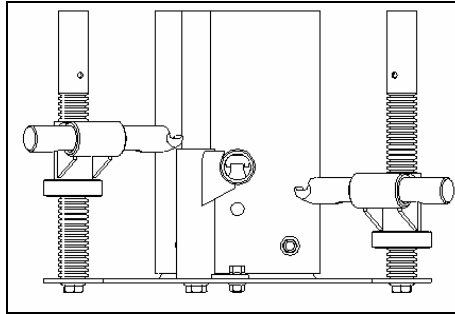

- B) Place strut assembly on the lower center hook using the lowest possible coil of the spring.

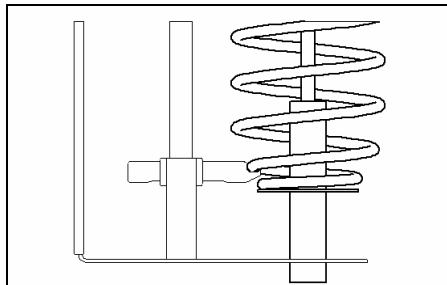

- C) Engage lower left and right hooks with spring. Center the spring within lower hooks. The three lower hooks should be equally extended.

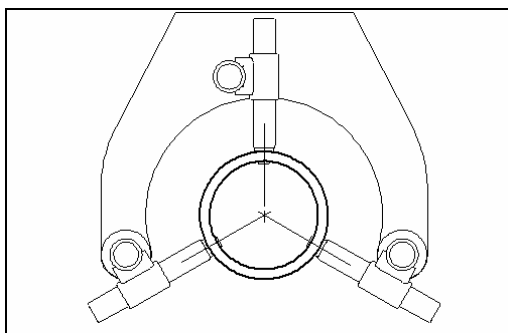

CORRECT

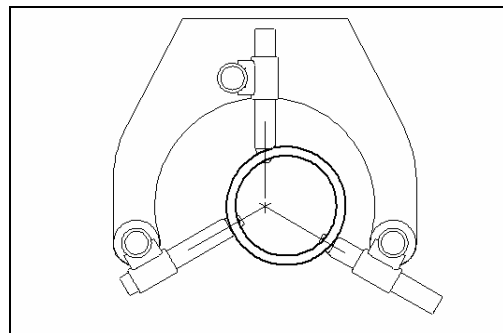

INCORRECT

D) Align strut assembly by adjusting the lower left and right hooks. When properly aligned, the spring of the strut assembly will be parallel to the posts of the tool when viewed from both the front and side.

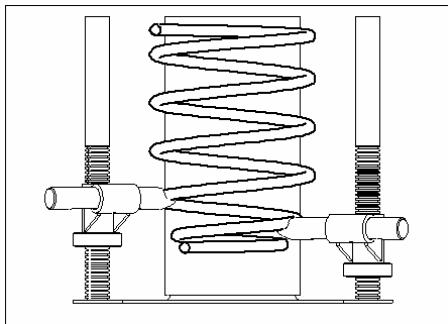

Front
CORRECT

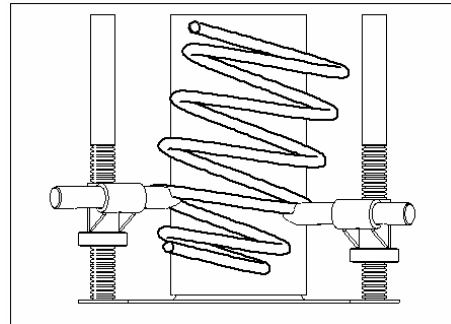

Front
INCORRECT

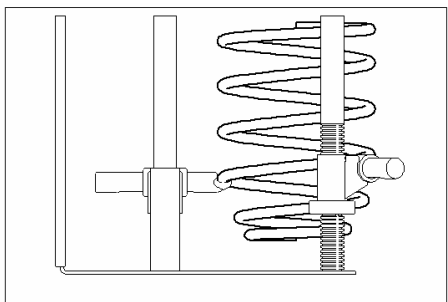

Side
CORRECT

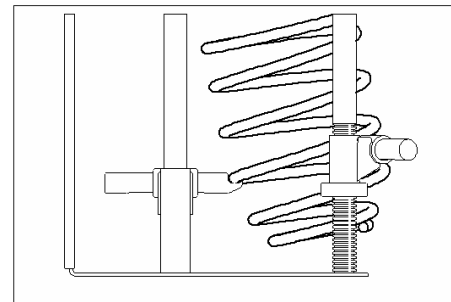

Side
INCORRECT

E) Identify the strut assembly type you are servicing.

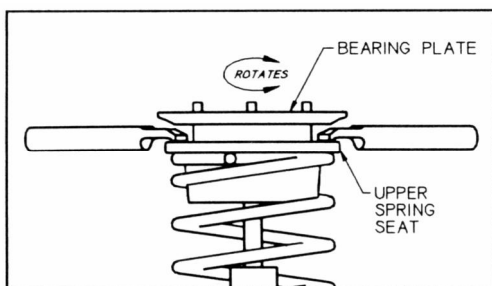

Type 1

This type of strut has a bearing plate (which rotates) and upper spring seat. Place upper hooks on the upper spring seat. **Do not place hooks on bearing plate.**

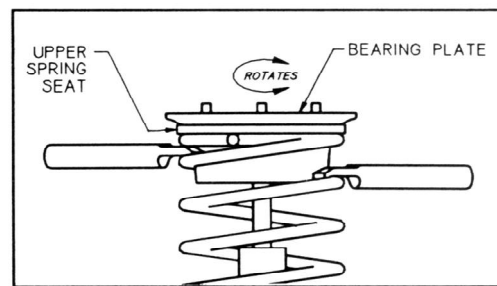

Type 2

This type of strut has a bearing plate (which rotates) and upper spring seat without space between them. Place upper hooks on the highest coil of the spring. **Do not place hooks on bearing plate.**

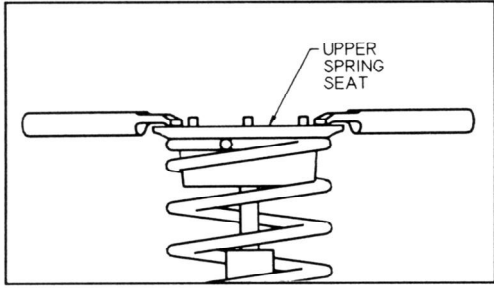

Type 3

This type of strut has only an upper spring seat. Place upper hooks on upper spring seat.

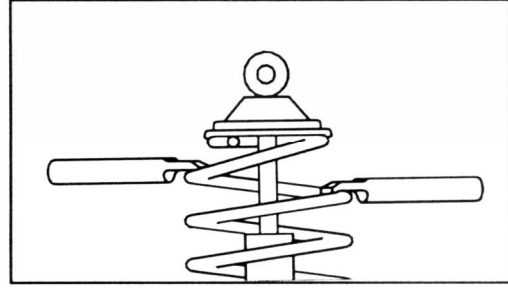

Type 4

This is a coil over shock. Place upper hooks on the highest coil of the spring.

F) Engage all three upper hooks as shown above for the type of strut assembly you are servicing. The three upper hooks should be equally extended and contacting the strut.

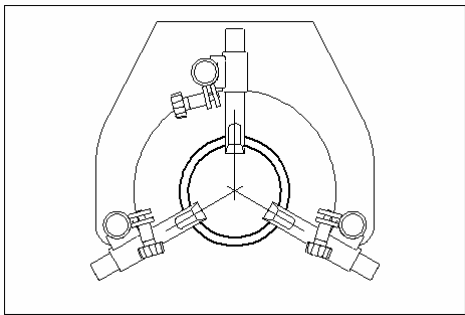

CORRECT

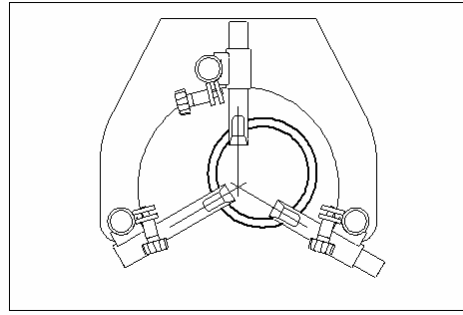

INCORRECT

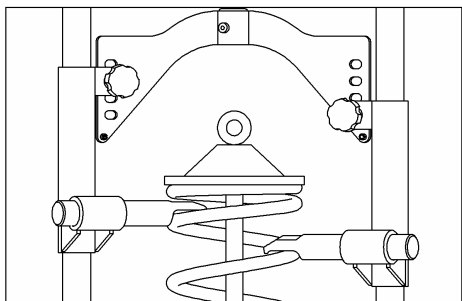

CORRECT

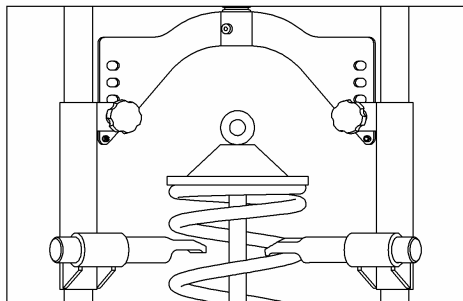

INCORRECT

Step 2. Disassembly

⚠ CAUTION

- ◆ **If the strut assembly is difficult to compress or the spring bows or tilts, release tension and reposition the strut assembly.**
- ◆ **Keep fingers and hands clear of the upper hook area at all times.**

A) With the strut assembly properly positioned, turn handles to compress spring until the bottom coil of spring is just free of the lower spring seat. **DO NOT OVER COMPRESS THE SPRING!**

B) Secure strut to spring with the clamp to prevent strut from dropping out unexpectedly.

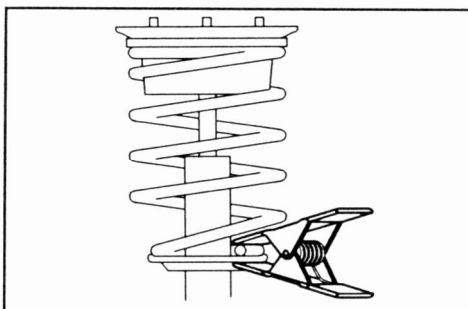

C) Mark upper strut parts to aid in reassembly.

⚠ WARNING

- ◆ **Use extreme care when working with a compressed spring.**
- ◆ **Never remove the piston rod nut when there is any spring pressure on the lower spring seat.**

D) Remove the piston rod nut.

E) Remove the clamp while holding strut. Carefully remove strut and related parts.

F) Service or replace strut as required. It is not necessary to release spring from tool when servicing strut only.

NOTE: When replacing top spring seat or spring, make note of the position of the spring seat and spring before releasing spring from tool. Replace new strut parts in tool in the same position as the old.

Step 3. Reassembly

- A) Position the new strut within spring. Secure strut to spring with the clamp.
- B) Install piston rod nut. **NUT MUST BE FULLY ENGAGED ON PISTON ROD THREADS!**
- C) Release pressure on spring. Remove the clamp. Remove strut assembly from tool.

MAINTENANCE

NOTE: To avoid personal injury or damage to the Model 7400, permit only qualified personnel to perform maintenance.

See repair parts breakdown for replacement parts.

- | | |
|----------------------|---|
| ALWAYS: | Keep hooks and pads free of oil and grease. |
| DAILY: | Inspect thrust bearing, drive screw, hooks, posts, lock pins and slots for wear. |
| MONTHLY: | Wipe down and clean ACME drive screw. |
| PERIODICALLY: | Inspect unit for loose or missing components. |
| YEARLY: | Clean and lightly lubricate thrust bearing. |
-

OWNER'S RECORDS

Date Installed: _____
Date Code _____ *Located under bottom plate*

REPAIR PARTS

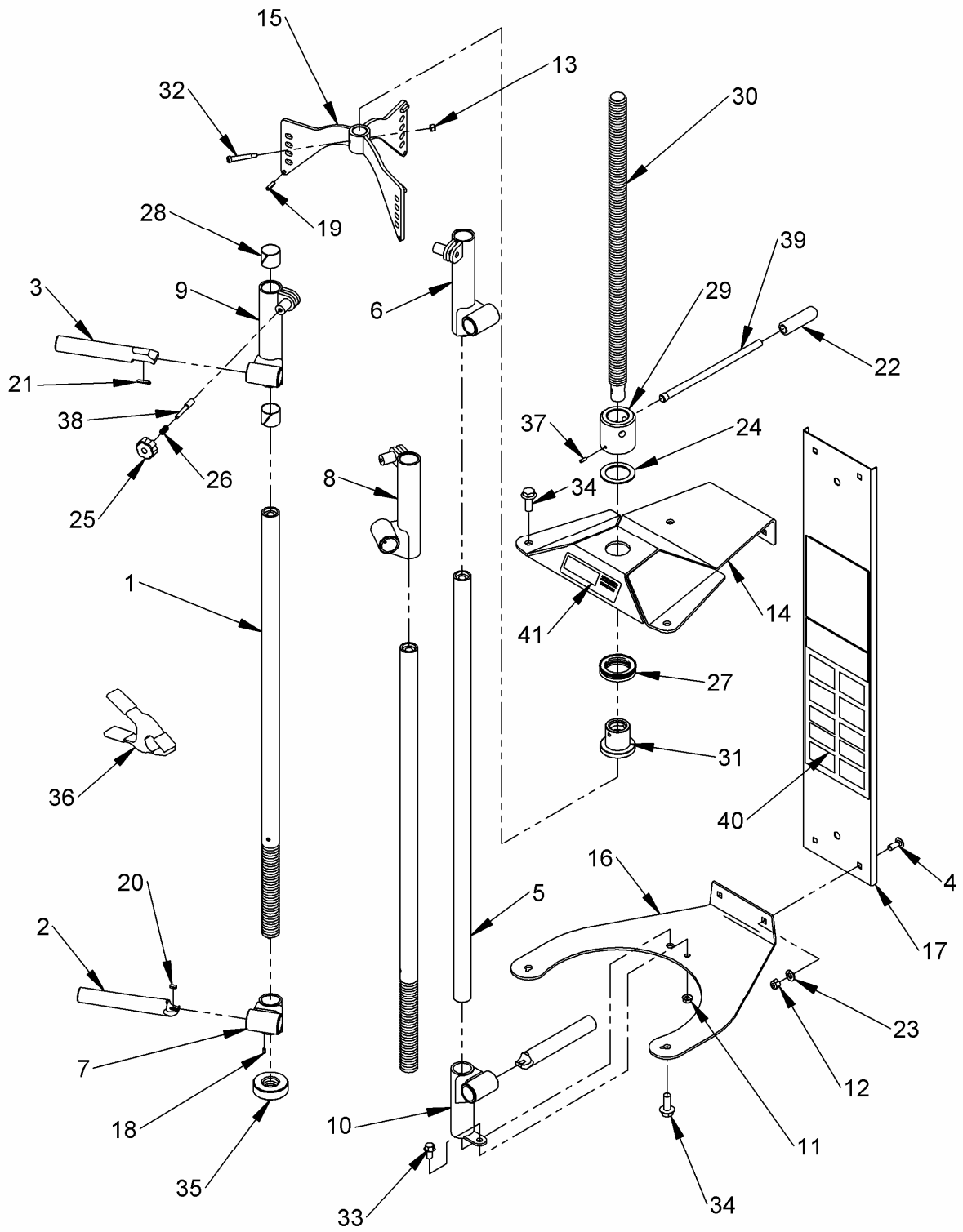

**MODEL 7400
SERVICE PARTS**

ITEM	PART NO.	QTY	DESCRIPTION
1	01-0085	2	POST
2	01-0242	3	LOWER HOOK
3	01-0243	3	UPPER HOOK
4	028-064	4	CARRIAGE BOLT, 3/8-16 X 1
5	03-0418	1	BACK POST
6	03-0420	1	UPPER REAR HOOK HOUSING
7	03-0423	2	ADJUSTABLE HOOK HOUSING
8	03-0425	1	UPPER RIGHT HOOK HOUSING
9	03-0426	1	UPPER LEFT HOOK HOUSING
10	03-0427	1	HOOK HOUSING
11	055-103	1	NUT, 3/8-16 SERRATED HEX FLANGE
12	055-154	4	NUT, 3/8-16 NYLON HEX LOCK
13	055-160	1	NUT, 1/4-20 NYLON HEX LOCK
14	06-0029	1	TOP PLATE
15	06-0030	1	COMPRESSION HEAD
16	06-0031	1	BOTTOM PLATE
17	06-0032	1	BACK PANEL
18	061-042	6	SPRING PIN, 3/16 X 3/8
19	061-091	3	SPRING PIN, 1/4 X 7/8
20	10-0011	3	HOOK PAD
21	10-0012	3	HOOK PAD
22	10-0022	3	HANDLE GRIP
23	108-015	4	WASHER, 3/8 SAE FLAT
24	108-137	1	WASHER, THRUST
25	11-0075	3	ADJUSTER KNOB
26	110-065	3	SPRING
27	20-0043	1	BEARING, THRUST BALL
28	20-0044	6	BEARING, NYLINER
29	21-0006	1	HANDLE HUB
30	21-0013	1	ACME DRIVE SCREW
31	21-0014	1	THREADED HUB
32	50-0025	1	SCREW, 5/16 X 1 SHOULDER
33	50-0065	1	SCREW, 3/8-16 x 3/4 SERRATED FLANGE
34	50-0068	6	SCREW, 1/2-13 X 1-1/4 SERRATED FLANGE
35	51-0015	2	ACME ADJUSTMENT NUT
36	53-0008	1	SPRING CLAMP
37	54-0010	2	SPRING PIN, 3/16 X 9/16
38	73-1000	3	LOCK PIN
39	73-1005	3	THREADED HANDLE ROD
40	80-0222	1	DECAL, INSTRUCTION
41	80-0224	1	DECAL, MODLE 7400
*	81-0103	1	INSTRUCTIONS, MODEL 7400 OPERATING

Branick Industries, Inc.

COMMERCIAL WARRANTY

This product is warranted by BRANICK INDUSTRIES, INC. to the original user-owner against defective materials or workmanship. During the warranty period, if Branick determines the product to be defective, it will be repaired or replaced (at Branick's option) without charge.

Warranty Period 1 year from date of delivery.

This warranty does not cover defects in the product caused by ordinary wear and tear, abuse, misuse, overloading, accident (including shipping damage), improper maintenance, alteration, or any other cause not the result of defective materials or workmanship.

REPLACEMENT IS THE EXCLUSIVE REMEDY FOR DEFECTIVE PRODUCT UNDER THIS WARRANTY. THIS WARRANTY IS EXPRESSLY IN LIEU OF ALL OTHER WARRANTIES, INCLUDING ANY IMPLIED WARRANTY OF MERCHANTABILITY OR ANY IMPLIED WARRANTY OF FITNESS FOR A PARTICULAR PURPOSE OF THIS PRODUCT. BRANICK INDUSTRIES, INC. SHALL NOT BE LIABLE FOR ANY CONSEQUENTIAL OR INCIDENTAL DAMAGES.

BRANICK INDUSTRIES, INC. reserves the right to make changes in the design or construction of our products without obligation to incorporate such changes in products already sold and without notice.

Service parts, warranty, and regular repair service are available from:

**BRANICK INDUSTRIES, INC.
4245 Main Ave.
Box 1937
Fargo, North Dakota 58107
701/281-8888**

Branick®
INDUSTRIES, Inc.